

18142-2
PERIMETER
 SURVEYING & MAPPING
 Certificate of Authorization No. LB7264
 Prepared by: Jeff S. Hodapp, P.S.M.
 947 Clint Moore Road
 Boca Raton, Florida 33487
 Tel: (561) 241-9988
 Fax: (561) 241-5182

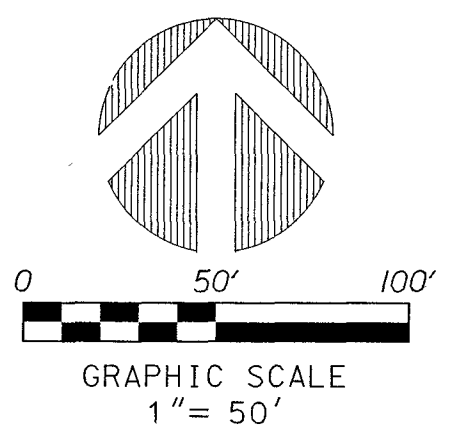

RESIDENCES AT BOCA DUNES P.U.D. REPLAT ONE

A REPLAT OF TRACTS A AND L, "RESIDENCES AT BOCA DUNES PUD", ACCORDING TO THE PLAT THEREOF, AS RECORDED IN PLAT BOOK 130 AT PAGES 14 THROUGH 21 OF THE PUBLIC RECORDS OF PALM BEACH COUNTY, FLORIDA, LYING IN SECTION 30, TOWNSHIP 47 SOUTH, RANGE 42 EAST, PALM BEACH COUNTY, FLORIDA.

33

**NOTES:
 COORDINATES, BEARINGS AND DISTANCES**

COORDINATES SHOWN ARE GRID
 DATUM - NAD 83 1990 ADJUSTMENT
 ZONE - FLORIDA EAST
 LINEAR UNIT - US SURVEY FOOT
 COORDINATE SYSTEM 1983 STATE PLANE
 TRANSVERSE MERCATOR PROJECTION
 ALL DISTANCES ARE GROUND, UNLESS OTHERWISE NOTED
 SCALE FACTOR = 1.000021
 GROUND DISTANCE X SCALE FACTOR = GRID DISTANCE
 BEARINGS AS SHOWN HEREON ARE GRID DATUM,
 NAD 83 1990 ADJUSTMENT, FLORIDA EAST ZONE

LEGEND:

- SET P.R.M. (UNLESS OTHERWISE NOTED)-4" x 4" CONC. MON. WITH ALUMINUM DISK STAMPED •LB7264 CENTERLINE
-
- ⊙
- ⊚
- ⊛
- ⊜
- ⊝
- ⊞
- ⊟
- ⊠
- ⊡
- ⊢
- ⊣
- ⊤
- ⊥
- ⊦
- ⊧
- ⊨
- ⊩
- ⊪
- ⊫
- ⊬
- ⊭
- ⊮
- ⊯
- ⊰
- ⊱
- ⊲
- ⊳
- ⊴
- ⊵
- ⊶
- ⊷
- ⊸
- ⊹
- ⊺
- ⊻
- ⊼
- ⊽
- ⊾
- ⊿
- ⋄
- ⋅
- ⋆
- ⋇
- ⋈
- ⋉
- ⋊
- ⋋
- ⋌
- ⋍
- ⋎
- ⋏
- ⋐
- ⋑
- ⋒
- ⋓
- ⋔
- ⋕
- ⋖
- ⋗
- ⋘
- ⋙
- ⋚
- ⋛
- ⋜
- ⋝
- ⋞
- ⋟
- ⋠
- ⋡
- ⋢
- ⋣
- ⋤
- ⋥
- ⋦
- ⋧
- ⋨
- ⋩
- ⋪
- ⋫
- ⋬
- ⋭
- ⋮
- ⋯
- ⋰
- ⋱
- ⋲
- ⋳
- ⋴
- ⋵
- ⋶
- ⋷
- ⋸
- ⋹
- ⋺
- ⋻
- ⋼
- ⋽
- ⋾
- ⋿
- Ⓢ
- Ⓣ
- Ⓤ
- Ⓥ
- Ⓦ
- Ⓧ
- Ⓨ
- Ⓩ
- ⓐ
- ⓑ
- ⓒ
- ⓓ
- ⓔ
- ⓕ
- ⓖ
- ⓗ
- ⓘ
- ⓙ
- ⓚ
- ⓛ
- ⓜ
- ⓝ
- ⓞ
- ⓟ
- ⓠ
- ⓡ
- ⓢ
- ⓣ
- ⓤ
- ⓥ
- ⓦ
- ⓧ
- ⓨ
- ⓩ
- ⓪
- ⓫
- ⓬
- ⓭
- ⓮
- ⓯
- ⓰
- ⓱
- ⓲
- ⓳
- ⓴
- ⓵
- ⓶
- ⓷
- ⓸
- ⓹
- ⓺
- ⓻
- ⓼
- ⓽
- ⓾
- ⓿
- (N.R.)

ABBREVIATIONS:

- CONC.
- COR.
- P.D.E.
- F.P.L.
- L.B.
- L.B.E.
- L.M.E.
- L.S.
- L.S.E.
- L.W.D.D.
- MON.
- O.R.B.
- P.B.
- P.B.C.R.
- PG.
- PGS.
- P.O.B.
- P.O.C.
- P.R.M.
- P.S.M.
- P.U.D.
- R.A.S.
- R.L.S.
- R/W
- SEC.
- U.E.
- PC
- PT
- PCC
- NT
- R
- L
- D
- (N.R.)
- CONCRETE
- CORNER
- PUBLIC DRAINAGE EASEMENT
- FLORIDA POWER AND LIGHT COMPANY
- LICENSED BUSINESS
- LANDSCAPE BUFFER EASEMENT
- LAKE MAINTENANCE EASEMENT
- LICENSED SURVEYOR
- LIFT STATION EASEMENT
- LAKE WORTH DRAINAGE DISTRICT
- MONUMENT
- OFFICIAL RECORDS BOOK
- PLAT BOOK
- PALM BEACH COUNTY RECORDS
- PAGE
- PAGES
- POINT OF BEGINNING
- POINT OF COMMENCEMENT
- PERMANENT REFERENCE MONUMENT
- PROFESSIONAL SURVEYOR & MAPPER
- PLANNED UNIT DEVELOPMENT
- RESIDENTIAL ACCESS STREET
- REGISTERED LAND SURVEYOR
- RIGHT-OF-WAY
- SECTION
- UTILITY EASEMENT
- POINT OF CURVATURE
- POINT OF TANGENCY
- POINT OF COMPOUND CURVATURE
- NON-TANGENT
- RADIAL
- ARCLENGTH
- DELTA (CENTRAL ANGLE)
- NON-RADIAL

SHEET 4 OF 5

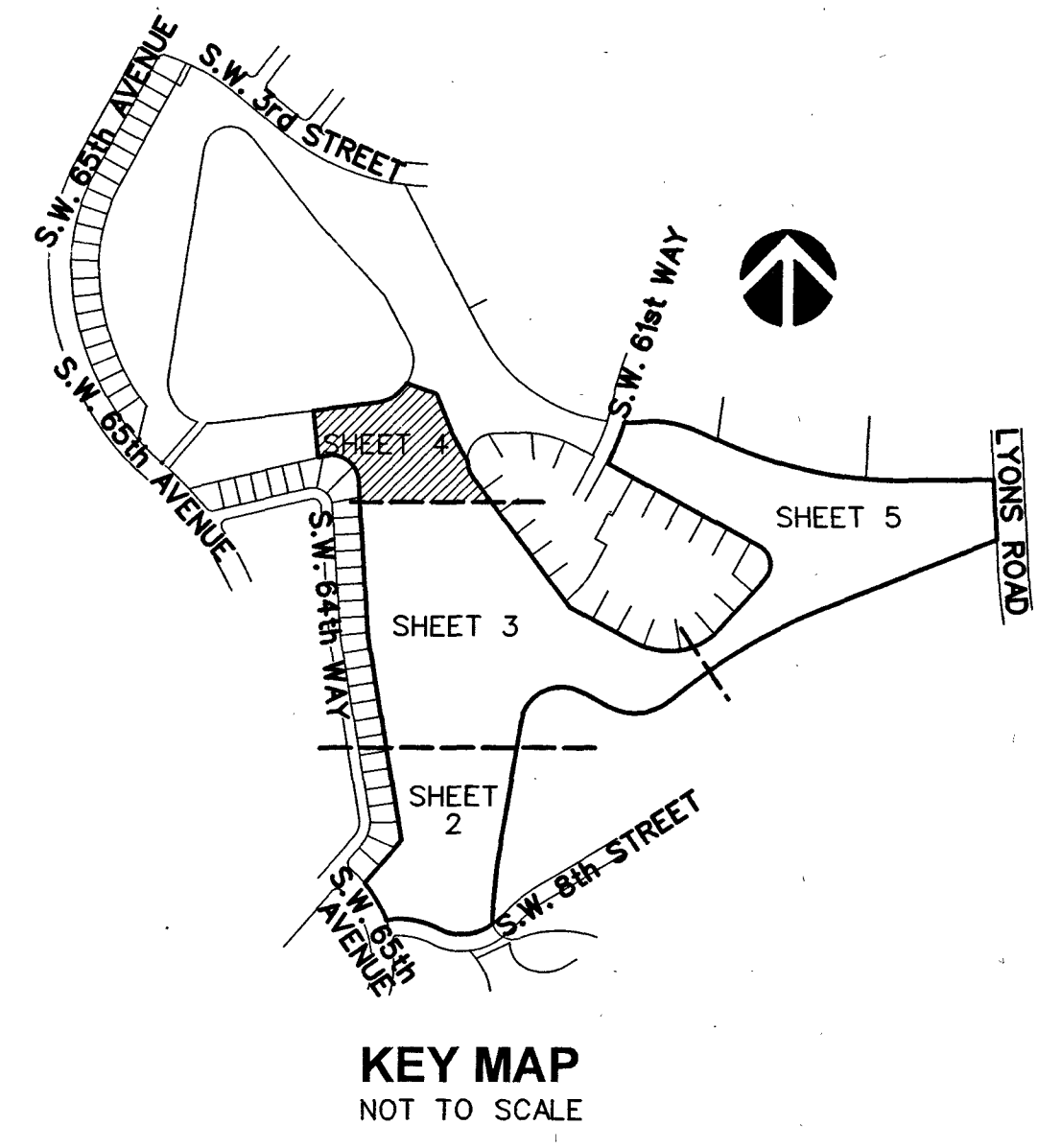
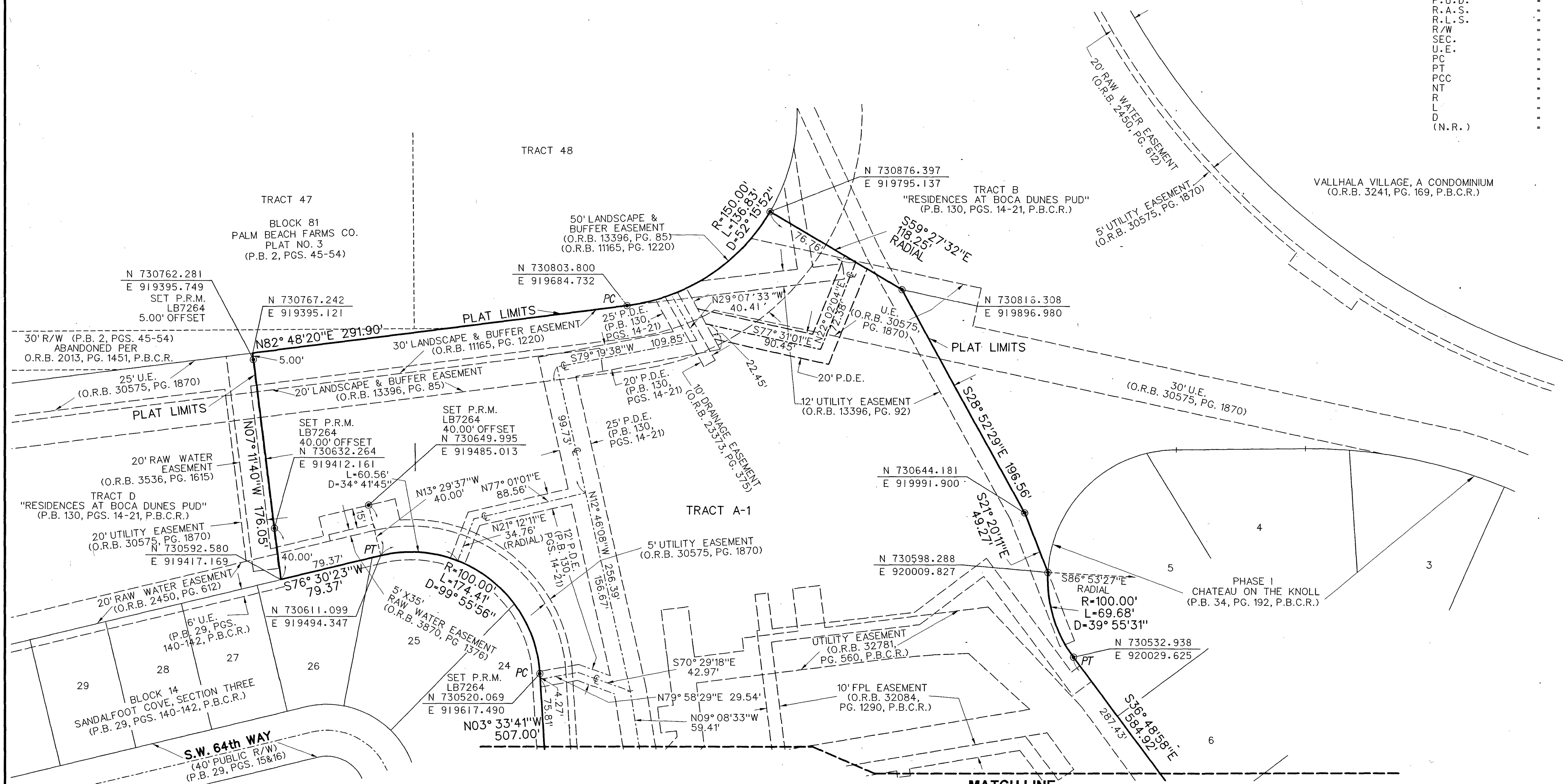

KEY MAP
 NOT TO SCALE

MATCH LINE
 (SEE SHEET 3)